

Programmable 1-PLL VCXO Clock Synthesizer With 1.8-V, 2.5-V, and 3.3-V Outputs

 Check for Samples: [CDCE913-Q1](#), [CDCEL913-Q1](#)

FEATURES

- Qualified for Automotive Applications
- AEC-Q100 Qualified With the Following Results:
 - Device Temperature Grade 1: –40°C to 125°C Ambient Operating Temperature Range
 - Device HBM ESD Classification Level H2
 - Device CDM ESD Classification Level C6
- Member of Programmable Clock Generator Family
 - CDCE913, CDCEL913: 1 PLL, 3 Outputs
 - CDCE925, CDCEL925: 2-PLL, 5 Outputs
 - CDCE937, CDCEL937: 3-PLL, 7 Outputs
 - CDCE949, CDCEL949: 4-PLL, 9 Outputs
- In-System Programmability and EEPROM
 - Serial Programmable Volatile Register
 - Nonvolatile EEPROM to Store Customer Settings
- Flexible Input Clocking Concept
 - External Crystal: 8 MHz to 32 MHz
 - On-Chip VCXO: Pull Range ±150 ppm
 - Single-Ended LVCMOS up to 160 MHz
- Free Selectable Output Frequency up to 230 MHz
- Low-Noise PLL Core
 - PLL Loop Filter Components Integrated
 - Low Period Jitter (Typical 50 ps)
- Separate Output Supply Pins
 - CDCE913-Q1: 3.3 V and 2.5 V
 - CDCEL913-Q1: 1.8 V
- Flexible Clock Driver
 - Three User-Definable Control Inputs [S0/S1/S2], for Example., SSC Selection, Frequency Switching, Output Enable, or Power Down
 - Generates Highly Accurate Clocks for Video, Audio, USB, IEEE1394, RFID, Bluetooth®, WLAN, Ethernet™, and GPS
 - Generates Common Clock Frequencies Used With TI- DaVinci™, OMAP™, DSPs
 - Programmable SSC Modulation
 - Enables 0-PPM Clock Generation
- 1.8-V Device Power Supply
- Wide Temperature Range –40°C to 125°C
- Packaged in TSSOP
- Development and Programming Kit for Easy PLL Design and Programming (TI Pro-Clock™)

APPLICATIONS

- D-TV, STB, IP-STB, DVD-Player, DVD-Recorder, Printer

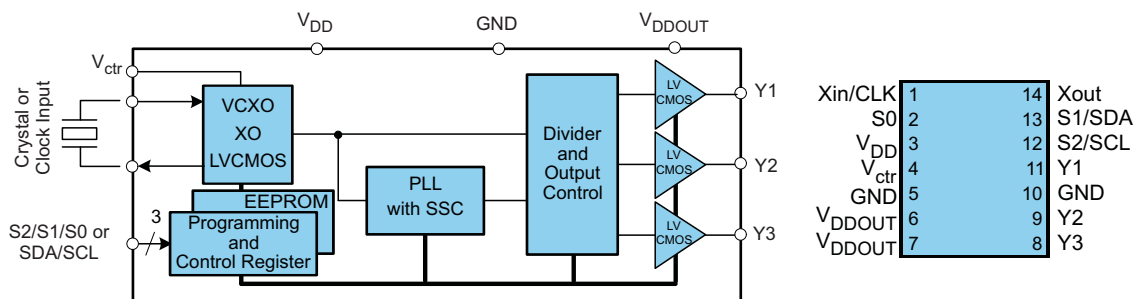

Please be aware that an important notice concerning availability, standard warranty, and use in critical applications of Texas Instruments semiconductor products and disclaimers thereto appears at the end of this data sheet.

DaVinci, OMAP, Pro-Clock are trademarks of Texas Instruments.

Bluetooth is a registered trademark of Bluetooth SIG, Inc..

Ethernet is a trademark of Xerox Corporation.

PRODUCT PREVIEW information concerns products in the formative or design phase of development. Characteristic data and other specifications are design goals. Texas Instruments reserves the right to change or discontinue these products without notice.

Copyright © 2013, Texas Instruments Incorporated



This integrated circuit can be damaged by ESD. Texas Instruments recommends that all integrated circuits be handled with appropriate precautions. Failure to observe proper handling and installation procedures can cause damage.

ESD damage can range from subtle performance degradation to complete device failure. Precision integrated circuits may be more susceptible to damage because very small parametric changes could cause the device not to meet its published specifications.

DESCRIPTION

The CDCE913-Q1 and CDCEL913-Q1 are modular PLL-based, low-cost, high-performance, programmable clock synthesizers, multipliers, and dividers. They generate up to three output clocks from a single input frequency. Each output can be programmed in-system for any clock frequency up to 230 MHz, using the integrated configurable PLL.

The CDCx913 has separate output supply pins, V_{DDOUT} , which is 1.8 V for CDCEL913-Q1 and 2.5 V to 3.3 V for CDCE913-Q1.

The input accepts an external crystal or LVCMOS clock signal. If an external crystal is used, an on-chip load capacitor is adequate for most applications. The value of the load capacitor is programmable from 0 to 20 pF. Additionally, a selectable on-chip VCXO allows synchronization of the output frequency to an external control signal, that is, the PWM signal.

The deep M/N divider ratio allows the generation of zero-ppm audio/video, networking (WLAN, *Bluetooth*, Ethernet, GPS) or interface (USB, IEEE1394, memory stick) clocks from, for example, a 27-MHz reference input frequency.

The PLL supports SSC (spread-spectrum clocking). SSC can be center-spread or down-spread clocking, which is a common technique to reduce electromagnetic interference (EMI).

Based on the PLL frequency and the divider settings, the internal loop filter components are automatically adjusted to achieve high stability and optimized jitter transfer characteristics.

The device supports non-volatile EEPROM programming for ease customization of the device to the application. It is preset to a factory default configuration (see the [DEFAULT DEVICE CONFIGURATION](#) section). It can be re-programmed to a different application configuration before PCB assembly, or re-programmed by in-system programming. All device settings are programmable through the SDA/SCL bus, a 2-wire serial interface.

Three programmable control inputs, S0, S1, and S2, can be used to select different frequencies, change SSC setting for lowering EMI, or control other features like outputs disable to low, outputs 3-state, power down, PLL bypass, etc).

The CDCx913 operates in a 1.8-V environment. It operates in a temperature range of -40°C to 125°C .

Terminal Functions for CDCE913-Q1, CDCEL913-Q1

TERMINAL		I/O	DESCRIPTION
NAME	PIN TSSOP14		
GND	5, 10	Ground	Ground
S0	2	I	User-programmable control input S0; LVCMOS inputs; 500-k Ω internal pullup
SCL/S2	12	I	SCL : serial clock input LVCMOS (default configuration), internal pullup 500 k Ω or S2 : user-programmable control input; LVCMOS inputs; 500-k Ω internal pullup
SDA/S1	13	I/O or I	SDA : bidirectional serial data input/output (default configuration), LVCMOS internal pullup; or S1 : user-programmable control input; LVCMOS inputs; 500-k Ω internal pullup
V_{Ctrl}	4	I	VCXO control voltage (leave open or pull up when not used)
V_{DD}	3	Power	1.8-V power supply for the device
V_{DDOUT}	6, 7	Power	CDCEL913-Q1 : 1.8-V supply for all outputs CDCE913-Q1 : 3.3-V or 2.5-V supply for all outputs
XinCLK	1	I	Crystal oscillator input or LVCMOS clock Input (selectable via SDA/SCL bus)
Xout	14	O	Crystal oscillator output (leave open or pull up when not used)
Y1–Y3	11, 9, 8	O	LVCMOS outputs

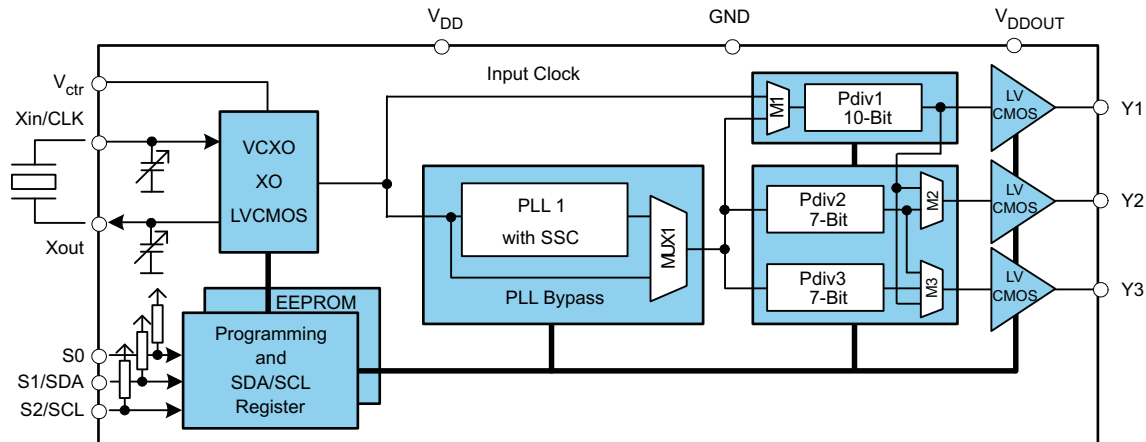

ABSOLUTE MAXIMUM RATINGS

over operating free-air temperature range (unless otherwise noted)⁽¹⁾

		VALUE	UNIT
V _{DD}	Supply voltage range	-0.5 to 2.5	V
V _I	Input voltage range ⁽²⁾ ⁽³⁾	-0.5 to V _{DD} + 0.5	V
V _O	Output voltage range ⁽²⁾	-0.5 to V _{DD} + 0.5	V
I _I	Input current (V _I < 0, V _I > V _{DD})	20	mA
I _O	Continuous output current	50	mA
T _{stg}	Storage temperature range	-65 to 150	°C
T _J	Maximum junction temperature	125	°C

- (1) Stresses beyond those listed under *Absolute Maximum Ratings* may cause permanent damage to the device. These are stress ratings only, and functional operation of the device at these or any other conditions beyond those indicated under *Recommended Operating Conditions* is not implied. Exposure to absolute-maximum-rated conditions for extended periods may affect device reliability.
- (2) The input and output negative voltage ratings may be exceeded if the input and output clamp-current ratings are observed.
- (3) SDA and SCL can go up to 3.6 V as stated in the *Recommended Operating Conditions* table.

THERMAL INFORMATION

THERMAL METRIC ⁽¹⁾		CDCE913-Q1, CDCEL913-Q1	UNIT
		PW	
		14 PINS	
θ _{JA}	Junction-to-ambient thermal resistance ⁽²⁾	110.6	°CW
θ _{JCtop}	Junction-to-case (top) thermal resistance ⁽³⁾	35.4	°CW
θ _{JB}	Junction-to-board thermal resistance ⁽⁴⁾	53.6	°CW
ψ _{JT}	Junction-to-top characterization parameter ⁽⁵⁾	2.1	°CW
ψ _{JB}	Junction-to-board characterization parameter ⁽⁶⁾	52.8	°CW

- (1) For more information about traditional and new thermal metrics, see the *IC Package Thermal Metrics* application report, [SPRA953](#).
- (2) The junction-to-ambient thermal resistance under natural convection is obtained in a simulation on a JEDEC-standard, high-K board, as specified in JESD51-7, in an environment described in JESD51-2a.
- (3) The junction-to-case (top) thermal resistance is obtained by simulating a cold plate test on the package top. No specific JEDEC-standard test exists, but a close description can be found in the ANSI SEMI standard G30-88.
- (4) The junction-to-board thermal resistance is obtained by simulating in an environment with a ring cold plate fixture to control the PCB temperature, as described in JESD51-8.
- (5) The junction-to-top characterization parameter, ψ_{JT}, estimates the junction temperature of a device in a real system and is extracted from the simulation data for obtaining θ_{JA}, using a procedure described in JESD51-2a (sections 6 and 7).
- (6) The junction-to-board characterization parameter, ψ_{JB}, estimates the junction temperature of a device in a real system and is extracted from the simulation data for obtaining θ_{JA}, using a procedure described in JESD51-2a (sections 6 and 7).

THERMAL INFORMATION (continued)

THERMAL METRIC ⁽¹⁾	CDCE913-Q1, CDCEL913-Q1	UNIT
	PW	
	14 PINS	
$\theta_{JCb\text{ot}}$ Junction-to-case (bottom) thermal resistance ⁽⁷⁾	NA	°CW

(7) The junction-to-case (bottom) thermal resistance is obtained by simulating a cold plate test on the exposed (power) pad. No specific JEDEC standard test exists, but a close description can be found in the ANSI SEMI standard G30-88.

PRODUCT PREVIEW

RECOMMENDED OPERATING CONDITIONS

		MIN	NOM	MAX	UNIT
V_{DD}	Device supply voltage	1.7	1.8	1.9	V
V_O	Output Yx supply voltage for CDCE913-Q1, V_{DDOUT}	2.3		3.6	V
	Output Yx supply voltage for CDCEL913-Q1, V_{DDOUT}	1.7		1.9	
V_{IL}	Low-level input voltage, LVCMOS			$0.3 V_{DD}$	V
V_{IH}	High-level input voltage, LVCMOS	$0.7 V_{DD}$			V
$V_{I(thresh)}$	Input voltage threshold, LVCMOS		$0.5 V_{DD}$		V
$V_{I(S)}$	Input voltage range, S0	0		1.9	V
	Input voltage range S1, S2, SDA, SCL; $V_{I(thresh)} = 0.5 V_{DD}$	0		3.6	
$V_{I(CLK)}$	Input voltage range CLK	0		1.9	V
I_{OH}, I_{OL}	Output current ($V_{DDOUT} = 3.3 V$)			± 12	mA
	Output current ($V_{DDOUT} = 2.5 V$)			± 10	
	Output current ($V_{DDOUT} = 1.8 V$)			± 8	
C_L	Output load, LVCMOS			15	pF
T_A	Operating free-air temperature	-40		125	°C

RECOMMENDED CRYSTAL AND VCXO SPECIFICATIONS⁽¹⁾

		MIN	NOM	MAX	UNIT
f_{Xtal}	Crystal input frequency range (fundamental mode)	8	27	32	MHz
ESR	Effective series resistance			100	Ω
f_{PR}	Pulling range ($0 V \leq V_{Ctrl} \leq 1.8 V$) ⁽²⁾	± 120	± 150		ppm
	Frequency control voltage, V_{Ctrl}	0		V_{DD}	V
C_0, C_1	Pullability ratio			220	
C_L	On-chip load capacitance at Xin and Xout	0		20	pF

(1) For more information about VCXO configuration, and crystal recommendation, see application report (SCAA085).

(2) Pulling range depends on crystal type, on-chip crystal load capacitance, and PCB stray capacitance; pulling range of minimum ± 120 ppm applies for crystal listed in the application report (SCAA085).

EEPROM SPECIFICATION

		MIN	TYP	MAX	UNIT
EEcyc	Programming cycles of EEPROM	100	1000		cycles
EEret	Data retention	10			years

TIMING REQUIREMENTS

over recommended ranges of supply voltage, load, and operating free-air temperature

			MIN	NOM	MAX	UNIT
CLK_IN REQUIREMENTS						
f_{CLK}	LVCMOS clock input frequency	PLL bypass mode	0		160	MHz
		PLL mode	8		160	
t_r, t_f	Rise and fall time CLK signal (20% to 80%)				3	ns
	Duty cycle CLK at $V_{DD} 2$		40%		60%	

		STANDARD MODE		FAST MODE		UNIT
		MIN	MAX	MIN	MAX	
SDA/SCL TIMING REQUIREMENTS (see Figure 12)						
f_{SCL}	SCL clock frequency	0	100	0	400	kHz
$t_{su}(START)$	START setup time (SCL high before SDA low)	4.7		0.6		μ s
$t_h(START)$	START hold time (SCL low after SDA low)	4		0.6		μ s
$t_w(SCLL)$	SCL low-pulse duration	4.7		1.3		μ s
$t_w(SCLH)$	SCL high-pulse duration	4		0.6		μ s
$t_h(SDA)$	SDA hold time (SDA valid after SCL low)	0	3.45	0	0.9	μ s
$t_{su}(SDA)$	SDA setup time	250		100		ns
t_r	SCL/SDA input rise time		1000		300	ns
t_f	SCL/SDA input fall time		300		300	ns
$t_{su}(STOP)$	STOP setup time	4		0.6		μ s
t_{BUS}	Bus free time between a STOP and START condition	4.7		1.3		μ s

DEVICE CHARACTERISTICS

over recommended operating free-air temperature range (unless otherwise noted)

PARAMETER		TEST CONDITIONS		MIN	TYP ⁽¹⁾	MAX	UNIT
OVERALL PARAMETER							
I _{DD}	Supply current (see Figure 3)	All outputs off, f _{CLK} = 27 MHz, f _{VCO} = 135 MHz; f _{OUT} = 27 MHz	All PLLS on		11		mA
			Per PLL		9		
I _{DD(OUT)}	Supply current (see Figure 4 and Figure 5)	No load, all outputs on, f _{OUT} = 27 MHz	V _{DDOUT} = 3.3 V		1.3		mA
			V _{DDOUT} = 1.8 V		0.7		
I _{DD(PD)}	Power-down current. Every circuit powered down except SDA/SCL	f _{IN} = 0 MHz,	V _{DD} = 1.9 V		30		μA
V _(PUC)	Supply voltage V _{DD} threshold for power-up control circuit			0.85		1.45	V
f _{VCO}	VCO frequency range of PLL			80		230	MHz
f _{OUT}	LVCMOS output frequency		V _{DDOUT} = 3.3 V			230	MHz
			V _{DDOUT} = 1.8 V			230	
LVCMOS PARAMETER							
V _{IK}	LVCMOS input voltage	V _{DD} = 1.7 V; I _I = -18 mA				-1.2	V
I _I	LVCMOS input current	V _I = 0 V or V _{DD} ; V _{DD} = 1.9 V				±5	μA
I _{IH}	LVCMOS input current for S0, S1, S2	V _I = V _{DD} ; V _{DD} = 1.9 V				5	μA
I _{IL}	LVCMOS input current for S0, S1, S2	V _I = 0 V; V _{DD} = 1.9 V				-4	μA
C _I	Input capacitance at XinCLK	V _{ICK} = 0 V or V _{DD}				6	pF
	Input capacitance at Xout	V _{IXout} = 0 V or V _{DD}				2	
	Input capacitance at S0, S1, S2	V _{IS} = 0 V or V _{DD}				3	
CDCE913-Q1 - LVCMOS PARAMETER FOR V_{DDOUT} = 3.3 V - MODE							
V _{OH}	LVCMOS high-level output voltage	V _{DDOUT} = 3 V, I _{OH} = -0.1 mA				2.9	V
		V _{DDOUT} = 3 V, I _{OH} = -8 mA				2.4	
		V _{DDOUT} = 3 V, I _{OH} = -12 mA				2.2	
V _{OL}	LVCMOS low-level output voltage	V _{DDOUT} = 3 V, I _{OL} = 0.1 mA				0.1	V
		V _{DDOUT} = 3 V, I _{OL} = 8 mA				0.5	
		V _{DDOUT} = 3 V, I _{OL} = 12 mA				0.8	
t _{PLH} , t _{PHL}	Propagation delay	PLL bypass				3.2	ns
t _r , t _f	Rise and fall time	V _{DDOUT} = 3.3 V (20%–80%)				0.6	ns
t _{jitter(cc)}	Cycle-to-cycle jitter ⁽²⁾ ⁽³⁾	1 PLL switching, Y2-to-Y3				50	200
t _{jitter(per)}	Peak-to-peak period jitter ⁽³⁾	1 PLL switching, Y2-to-Y3				60	200
t _{sk(o)}	Output skew ⁽⁴⁾ , See Table 2	f _{OUT} = 50 MHz; Y1-to-Y3					440
odc	Output duty cycle ⁽⁵⁾	f _{VCO} = 100 MHz; Pdiv = 1				45%	55%
CDCE913-Q1 - LVCMOS PARAMETER for V_{DDOUT} = 2.5 V - Mode							
V _{OH}	LVCMOS high-level output voltage	V _{DDOUT} = 2.3 V, I _{OH} = -0.1 mA				2.2	V
		V _{DDOUT} = 2.3 V, I _{OH} = -6 mA				1.7	
		V _{DDOUT} = 2.3 V, I _{OH} = -10 mA				1.6	
V _{OL}	LVCMOS low-level output voltage	V _{DDOUT} = 2.3 V, I _{OL} = 0.1 mA				0.1	V
		V _{DDOUT} = 2.3 V, I _{OL} = 6 mA				0.5	
		V _{DDOUT} = 2.3 V, I _{OL} = 10 mA				0.7	
t _{PLH} , t _{PHL}	Propagation delay	PLL bypass				3.6	ns
t _r , t _f	Rise and fall time	V _{DDOUT} = 2.5 V (20%–80%)				0.8	ns
t _{jitter(cc)}	Cycle-to-cycle jitter ⁽²⁾ ⁽³⁾	1 PLL switching, Y2-to-Y3				50	200
t _{jitter(per)}	Peak-to-peak period jitter ⁽³⁾	1 PLL switching, Y2-to-Y3				60	200
t _{sk(o)}	Output skew ⁽⁴⁾ , See Table 2	f _{OUT} = 50 MHz; Y1-to-Y3					440
odc	Output duty cycle ⁽⁵⁾	f _{VCO} = 100 MHz; Pdiv = 1				45%	55%
CDCEL913-Q1 - LVCMOS PARAMETER for V_{DDOUT} = 1.8 V - Mode							

 (1) All typical values are at respective nominal V_{DD}.

(2) 10,000 cycles.

 (3) Jitter depends on configuration. Jitter data is for input frequency = 27 MHz, f_{VCO} = 108 MHz, f_{OUT} = 27 MHz (measured at Y2).

 (4) The t_{sk(o)} specification is only valid for equal loading of each bank of outputs, and the outputs are generated from the same divider.

 (5) odc depends on output rise and fall time (t_r, t_f); data sampled on rising edge (t_r)

DEVICE CHARACTERISTICS (continued)

over recommended operating free-air temperature range (unless otherwise noted)

PARAMETER		TEST CONDITIONS	MIN	TYP ⁽¹⁾	MAX	UNIT
V _{OH}	LVCMOS high-level output voltage	V _{DDOUT} = 1.7 V, I _{OH} = -0.1 mA	1.6			V
		V _{DDOUT} = 1.7 V, I _{OH} = -4 mA	1.4			
		V _{DDOUT} = 1.7 V, I _{OH} = -8 mA	1.1			
V _{OL}	LVCMOS low-level output voltage	V _{DDOUT} = 1.7 V, I _{OL} = 0.1 mA			0.1	V
		V _{DDOUT} = 1.7 V, I _{OL} = 4 mA			0.3	
		V _{DDOUT} = 1.7 V, I _{OL} = 8 mA			0.6	
t _{PLH} , t _{PHL}	Propagation delay	PLL bypass		2.6		ns
t _r , t _f	Rise and fall time	V _{DDOUT} = 1.8 V (20%–80%)		0.7		ns
t _{jit(cc)}	Cycle-to-cycle jitter ⁽⁶⁾ ⁽⁷⁾	1 PLL switching, Y2-to-Y3		80	110	ps
t _{jit(per)}	Peak-to-peak period jitter ⁽⁷⁾	1 PLL switching, Y2-to-Y3		100	130	ps
t _{sk(o)}	Output skew ⁽⁸⁾ , See Table 2	f _{OUT} = 50 MHz; Y1-to-Y3			50	ps
odc	Output duty cycle ⁽⁹⁾	f _{VCO} = 100 MHz; Pdiv = 1	45%		55%	
SDA/SCL PARAMETER						
V _{IK}	SCL and SDA input clamp voltage	V _{DD} = 1.7 V; I _I = -18 mA			-1.2	V
I _{IH}	SCL and SDA input current	V _I = V _{DD} ; V _{DD} = 1.9 V			±10	µA
V _{IH}	SDA/SCL input high voltage ⁽¹⁰⁾		0.7 V _{DD}			V
V _{IL}	SDA/SCL input low voltage ⁽¹⁰⁾				0.3 V _{DD}	V
V _{OL}	SDA low-level output voltage	I _{OL} = 3 mA, V _{DD} = 1.7 V			0.2 V _{DD}	V
C _I	SCL/SDA input capacitance	V _I = 0 V or V _{DD}		3	10	pF

(6) 10,000 cycles.

(7) Jitter depends on configuration. Jitter data is for input frequency = 27 MHz, f_{VCO} = 108 MHz, f_{OUT} = 27 MHz (measured at Y2).

(8) The t_{sk(o)} specification is only valid for equal loading of each bank of outputs, and the outputs are generated from the same divider.

(9) odc depends on output rise and fall time (t_r, t_f); data sampled on rising edge (t_r)

(10) SDA and SCL pins are 3.3-V tolerant.

PRODUCT PREVIEW

PARAMETER MEASUREMENT INFORMATION

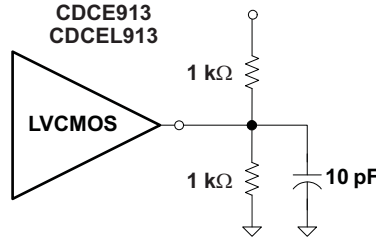

Figure 1. Test Load

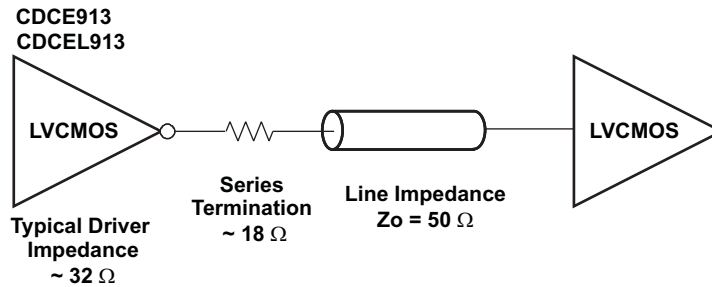

Figure 2. Test Load for 50-Ω Board Environment

TYPICAL CHARACTERISTICS

CDCE913-Q1, CDCEL913-Q1
SUPPLY CURRENT
vs
PLL FREQUENCY

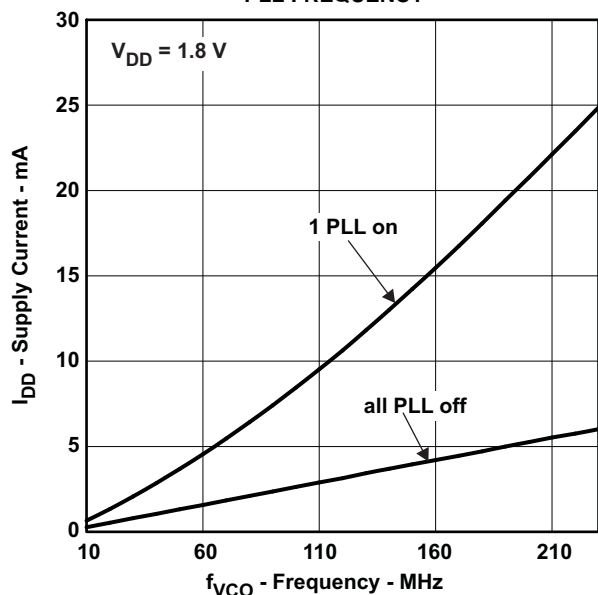

Figure 3.

CDCE913-Q1
OUTPUT CURRENT
vs
OUTPUT FREQUENCY

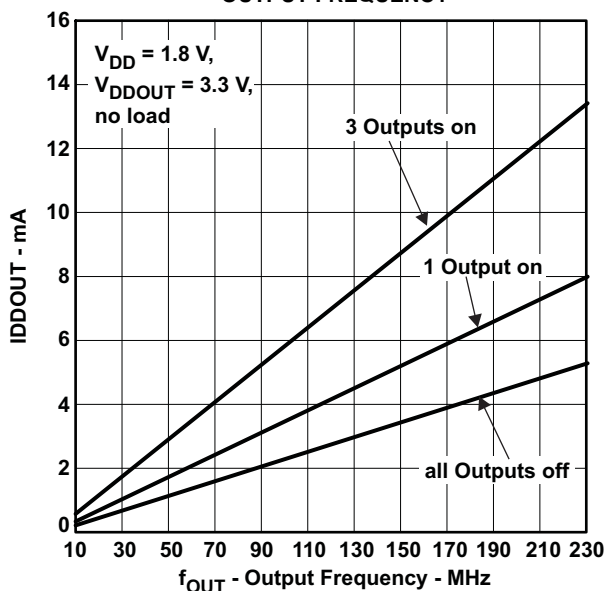

Figure 4.

CDCEL913-Q1
OUTPUT CURRENT
vs
OUTPUT FREQUENCY

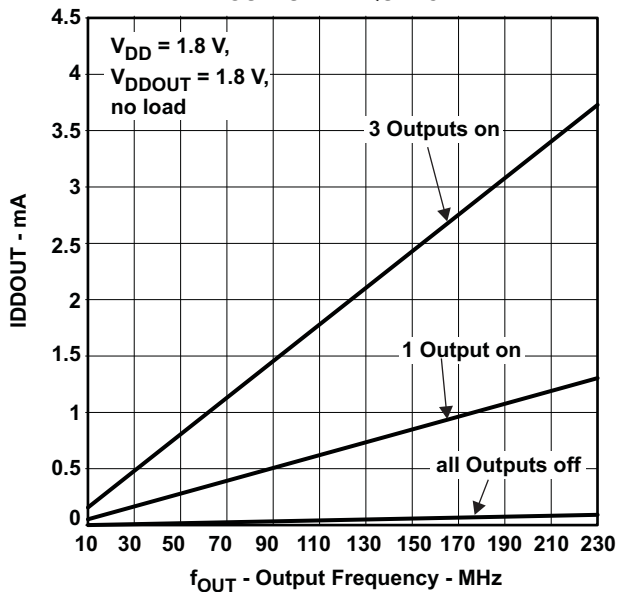

Figure 5.

PRODUCT PREVIEW

APPLICATION INFORMATION

CONTROL TERMINAL CONFIGURATION

The CDCE913-Q1 and CDCEL913-Q1 have three user-definable control terminals (S0, S1, and S2), which allow external control of device settings. They can be programmed to any of the following functions:

- Spread-spectrum clocking selection → spread type and spread amount selection
- Frequency selection → switching between any of two user-defined frequencies
- Output state selection → output configuration and power-down control

The user can predefine up to eight different control settings. [Table 1](#) and [Table 2](#) explain these settings.

Table 1. Control Terminal Definition

External Control Bits	PLL1 Setting			Y1Setting
Control function	PLL frequency selection	SSC selection	Output Y2, Y3 selection	Output Y1 and power-down selection

Table 2. PLLx Setting (Can Be Selected for Each PLL Individually)⁽¹⁾

SSC Selection (Center and Down)				
SSCx [3 Bits]			Center	Down
0	0	0	0% (off)	0% (off)
0	0	1	±0.25%	-0.25%
0	1	0	±0.5%	-0.5%
0	1	1	±0.75%	-0.75%
1	0	0	±1.0%	-1.0%
1	0	1	±1.25%	-1.25%
1	1	0	±1.5%	-1.5%
1	1	1	±2.0%	-2.0%
FREQUENCY SELECTION ⁽²⁾				
FSx		FUNCTION		
0		Frequency0		
1		Frequency1		
OUTPUT SELECTION ⁽³⁾ (Y2 ... Y3)				
YxYx		FUNCTION		
0		State0		
1		State1		

- (1) Center- and down-spread, Frequency0-Frequency1, and State0-State1 are user-definable in the PLLx configuration register.
- (2) Frequency0 and Frequency1 can be any frequency within the specified f_{VCO} range.
- (3) State0-State1 selection is valid for both outputs of the corresponding PLL module and can be power down, 3-state, low, or active.

Table 3. Y1 Setting⁽¹⁾

Y1 SELECTION	
Y1	FUNCTION
0	State0
1	State1

- (1) State0 and State1 are user definable in the generic configuration register and can be power down, 3-state, low, or active.

The S1SDA and S2SCL pins of the CDCE913-Q1 and CDCEL913-Q1 are dual-function pins. In the default configuration, they are defined as SDA/SCL for the serial programming interface. They can be programmed as control pins (S1 and S2) by setting the appropriate bits in the EEPROM. Note that changes to the control register (Bit [6] of byte **02h**) have no effect until they are written into the EEPROM.

Once they are set as control pins, the serial programming interface is no longer available. However, if V_{DDOUT} is forced to GND, the two control pins, S1 and S2, temporarily act as serial programming pins (SDA/SCL).

S0 is **not** a multi-use pin; it is a control pin only.

DEFAULT DEVICE CONFIGURATION

The internal EEPROM of CDCE913-Q1 and CDCEL913-Q1 is pre-configured with a factory default configuration as shown in Figure 6 (The input frequency is passed through the output as a default). This allows the device to operate in default mode without the extra production step of programming it. The default setting appears after power is supplied or after a power-down and power-up sequence until the device is reprogrammed by the user to a different application configuration. A new register setting is programmed via the serial SDA/SCL interface.

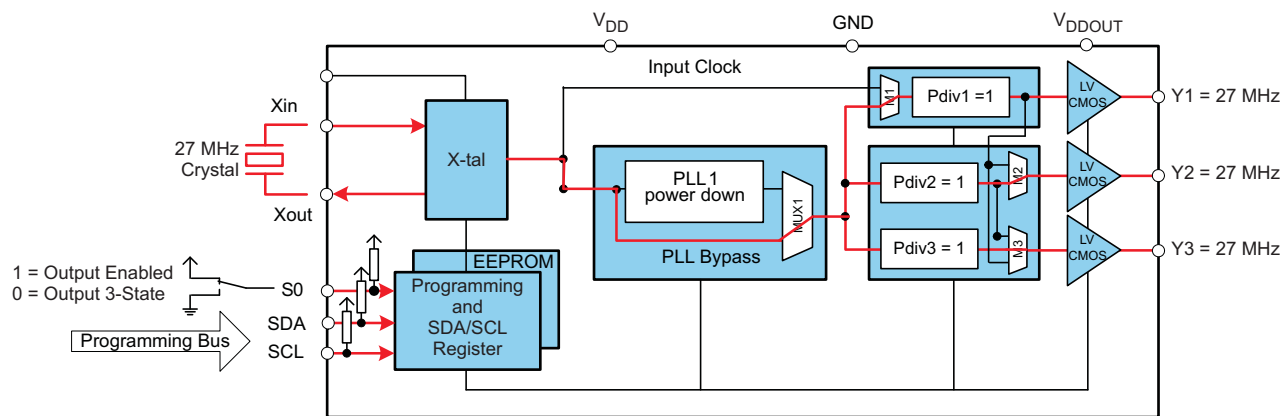

Figure 6. Default Configuration

Table 4 shows the factory default setting for the Control Terminal Register. Note that even though eight different register settings are possible, in the default configuration, only the first two settings (0 and 1) can be selected with S0, as S1 and S2 are configured as programming pins in default mode.

Table 4. Factory Default Setting for Control Terminal Register⁽¹⁾

External Control Pins			Y1	PLL1 Settings		
S2	S1	S0	Output Selection	Frequency Selection	SSC Selection	Output Selection
SCL (I2C)	SDA (I2C)	0	Y1	f_{VCO1_0}	SSC1	Y2Y3
SCL (I2C)	SDA (I2C)	1	3-state	f_{VCO1_0}	off	3-state
SCL (I2C)	SDA (I2C)	1	Enabled	f_{VCO1_0}	off	Enabled

(1) In default mode or when programmed respectively, S1 and S2 act as serial programming interface, SDA/SCL. They do not have any control-pin function but they are internally interpreted as if S1 = 0 and S2 = 0. S0, however, is a control pin, which in the default mode switches all outputs ON or OFF (as previously predefined).

SDA/SCL SERIAL INTERFACE

The CDCE913-Q1 and CDCEL913-Q1 operate as a slave device of the 2-wire serial SDA/SCL bus, compatible with the popular SMBus or I²C specification. It operates in the standard-mode transfer (up to 100 kbits) and fast-mode transfer (up to 400 kbits) and supports 7-bit addressing.

The S1SDA and S2SCL pins of the CDCE913-Q1 and CDCEL913-Q1 are dual-function pins. In the default configuration, they are used as the SDA/SCL serial programming interface. They can be re-programmed as general-purpose control pins, S1 and S2, by changing the corresponding EEPROM setting, byte **02h**, bit [6].

DATA PROTOCOL

The device supports *Byte Write and Byte Read* and *Block Write and Block Read* operations.

For *Byte WriteRead* operations, the system controller can individually access addressed bytes.

For *Block WriteRead* operations, the bytes are accessed in sequential order from lowest to highest byte (with most-significant bit first) with the ability to stop after any complete byte has been transferred. The numbers of bytes read out are defined by Byte Count in the generic configuration register. At the *Block Read* instruction, all bytes defined in Byte Count must be read out to finish the read cycle correctly.

Once a byte has been sent, it is written into the internal register and is effective immediately. This applies to each transferred byte, regardless of whether this is a *Byte Write* or a *Block Write* sequence.

If the EEPROM write cycle is initiated, the internal SDA registers are written into the EEPROM. During this write cycle, data is not accepted at the SDA/SCL bus until the write cycle is completed. However, data can be read out during the programming sequence (*Byte Read* or *Block Read*). The programming status can be monitored by *EEPIP*, byte 01h–bit 6.

The offset of the indexed byte is encoded in the command code, as described in [Table 5](#).

Table 5. Slave Receiver Address (7 Bits)

DEVICE	A6	A5	A4	A3	A2	A1 ⁽¹⁾	A0 ⁽¹⁾	R/W
CDCE913-Q1, CDCEL913-Q1	1	1	0	0	1	0	1	10
CDCE925, CDCEL925	1	1	0	0	1	0	0	10
CDCE937, CDCEL937	1	1	0	1	1	0	1	10
CDCE949, CDCEL949	1	1	0	1	1	0	0	10

(1) Address bits A0 and A1 are programmable via the SDA/SCL bus (byte 01, bits [1:0]). This allows addressing up to 4 devices connected to the same SDA/SCL bus. The least-significant bit of the address byte designates a write or read operation.

COMMAND CODE DEFINITION

Table 6. Command Code Definition

BIT	DESCRIPTION
7	0 = <i>Block Read</i> or <i>Block Write</i> operation 1 = <i>Byte Read</i> or <i>Byte Write</i> operation
(6:0)	Byte offset for <i>Byte Read</i> , <i>Block Read</i> , <i>Byte Write</i> , and <i>Block Write</i> operations

Generic Programming Sequence

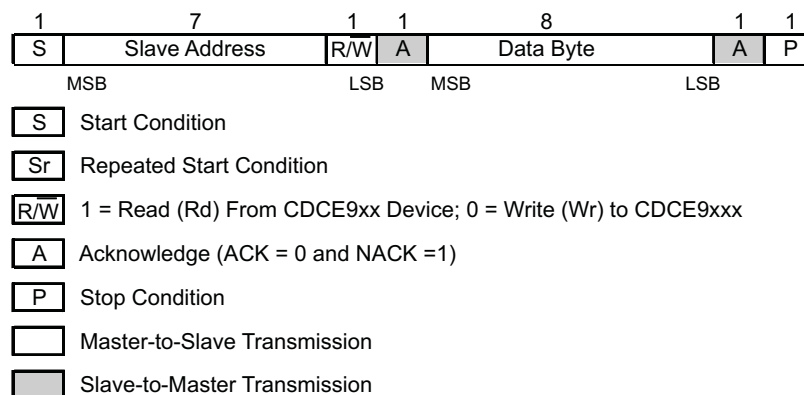

Figure 7. Generic Programming Sequence

Byte Write Programming Sequence



Figure 8. Byte Write Protocol

Byte Read Programming Sequence

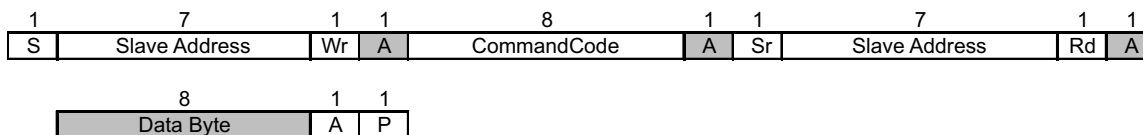
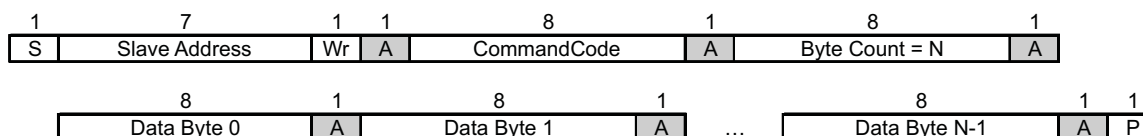

Figure 9. Byte Read Protocol

Block Write Programming Sequence



- (1) Data byte 0 bits [7:0] is reserved for Revision Code and Vendor Identification. Also, it is used for internal test purpose and should not be overwritten.

Figure 10. Block Write Protocol

Block Read Programming Sequence

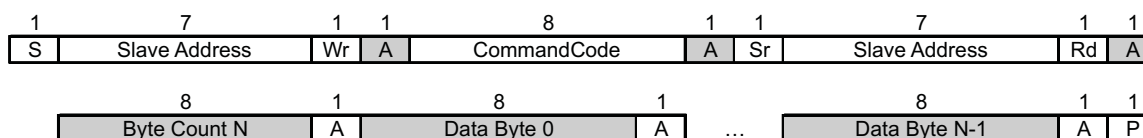

Figure 11. Block Read Protocol

Timing Diagram for the SDA/SCL Serial Control Interface

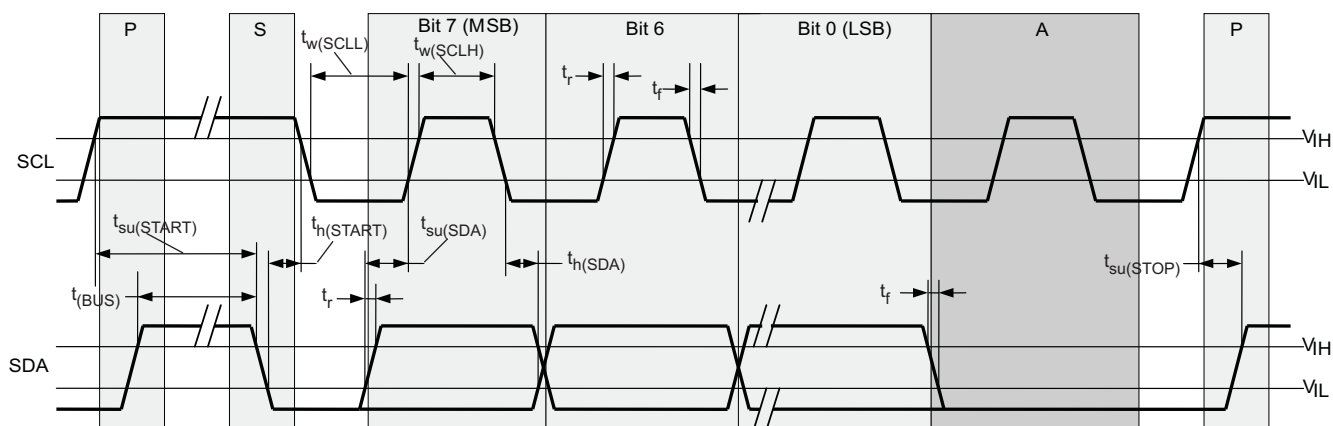

Figure 12. Timing Diagram for SDA/SCL Serial Control Interface

SDA/SCL HARDWARE INTERFACE

Figure 13 shows how the CDCE913-Q1 and CDCEL913-Q1 clock synthesizer is connected to the SDA/SCL serial interface bus. Multiple devices can be connected to the bus, but it may be necessary to reduce the speed (400 kHz is the maximum) if many devices are connected.

Note that the pullup resistors (R_P) depend on the supply voltage, bus capacitance, and number of connected devices. The recommended pullup value is 4.7 k Ω . It must meet the minimum sink current of 3 mA at $V_{OLmax} = 0.4$ V for the output stages (for more details see the SMBus or I²C Bus specification).

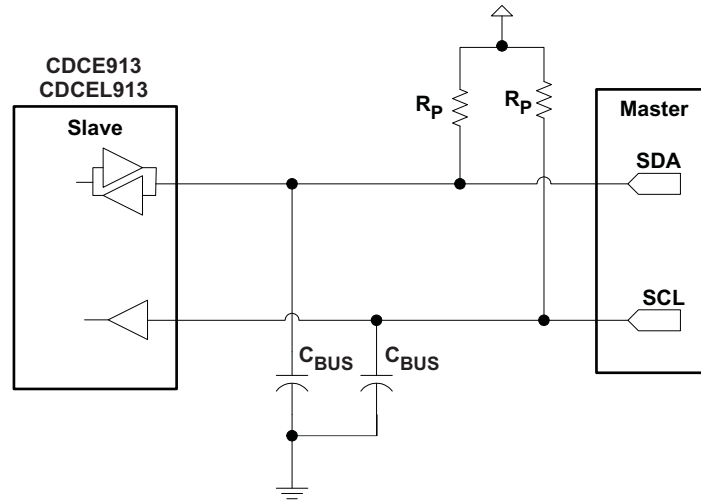

Figure 13. SDA SCL Hardware Interface

SDA/SCL CONFIGURATION REGISTERS

The clock input, control pins, PLLs, and output stages are user configurable. The following tables and explanations describe the programmable functions of the CDCE913-Q1 and CDCEL913-Q1. All settings can be manually written into the device via the SDA/SCL bus or easily programmed by using the TI Pro-Clock™ software. TI Pro-Clock™ software allows the user to quickly make all settings and automatically calculates the values for optimized performance at lowest jitter.

Table 7. SDA/SCL Registers

Address Offset	Register Description	Table
00h	Generic configuration register	Table 9
10h	PLL1 configuration register	Table 10

The grey-highlighted bits, described in the configuration register tables in the following pages, belong to the control terminal register. The user can predefine up to eight different control settings. These settings then can be selected by the external control pins, S0, S1, and S2. See the [Control Terminal Configuration](#) section.

**Table 8. Configuration Register,
External Control Terminals**

	External Control Pins			Y1	PLL1 Settings		
				Output Selection	Frequency Selection	SSC Selection	Output Selection
	S2	S1	S0	Y1	FS1	SSC1	Y2Y3
0	0	0	0	Y1_0	FS1_0	SSC1_0	Y2Y3_0
1	0	0	1	Y1_1	FS1_1	SSC1_1	Y2Y3_1
2	0	1	0	Y1_2	FS1_2	SSC1_2	Y2Y3_2
3	0	1	1	Y1_3	FS1_3	SSC1_3	Y2Y3_3
4	1	0	0	Y1_4	FS1_4	SSC1_4	Y2Y3_4
5	1	0	1	Y1_5	FS1_5	SSC1_5	Y2Y3_5
6	1	1	0	Y1_6	FS1_6	SSC1_6	Y2Y3_6
7	1	1	1	Y1_7	FS1_7	SSC1_7	Y2Y3_7
	Address offset ⁽¹⁾			04h	13h	10h–12h	15h

(1) Address offset refers to the byte address in the configuration register in [Table 9](#) and [Table 10](#).

Table 9. Generic Configuration Register (continued)

Offset ⁽¹⁾	Bit ⁽²⁾	Acronym	Default ⁽³⁾	Description
06h	7:1	BCOUNT	20h	7-bit byte count (defines the number of bytes which will be sent from this device at the next <i>Block Read</i> transfer); all bytes must be read out to finish the read cycle correctly.
	0	EEWRITE	0b	Initiate EEPROM write cycle ⁽⁴⁾ ⁽⁹⁾ 0 – No EEPROM write cycle 1 – Start EEPROM write cycle (internal registers are saved to the EEPROM)
07h-0Fh		—	0h	Unused address range

- (9) The EEPROM WRITE bit must be sent last. This ensures that the content of all internal registers are stored in the EEPROM. The EEWRITE cycle is initiated with the rising edge of the EEWRITE bit. A static level-high does not trigger an EEPROM WRITE cycle. The EEWRITE bit must be reset to low after the programming is completed. The programming status can be monitored by reading out EEPIP. If EELOCK is set to high, no EEPROM programming is possible.

Table 10. PLL1 Configuration Register

OFFSET ⁽¹⁾	Bit ⁽²⁾	Acronym	Default ⁽³⁾	DESCRIPTION																		
10h	7:5	SSC1_7 [2:0]	000b	SSC1: PLL1 SSC selection (modulation amount). ⁽⁴⁾ <table border="0"> <tr> <td style="text-align: center;">Down</td> <td style="text-align: center;">Center</td> </tr> <tr> <td>000 (off)</td> <td>000 (off)</td> </tr> <tr> <td>001 – 0.25%</td> <td>001 ± 0.25%</td> </tr> <tr> <td>010 – 0.5%</td> <td>010 ± 0.5%</td> </tr> <tr> <td>011 – 0.75%</td> <td>011 ± 0.75%</td> </tr> <tr> <td>100 – 1.0%</td> <td>100 ± 1.0%</td> </tr> <tr> <td>101 – 1.25%</td> <td>101 ± 1.25%</td> </tr> <tr> <td>110 – 1.5%</td> <td>110 ± 1.5%</td> </tr> <tr> <td>111 – 2.0%</td> <td>111 ± 2.0%</td> </tr> </table>	Down	Center	000 (off)	000 (off)	001 – 0.25%	001 ± 0.25%	010 – 0.5%	010 ± 0.5%	011 – 0.75%	011 ± 0.75%	100 – 1.0%	100 ± 1.0%	101 – 1.25%	101 ± 1.25%	110 – 1.5%	110 ± 1.5%	111 – 2.0%	111 ± 2.0%
	Down	Center																				
	000 (off)	000 (off)																				
001 – 0.25%	001 ± 0.25%																					
010 – 0.5%	010 ± 0.5%																					
011 – 0.75%	011 ± 0.75%																					
100 – 1.0%	100 ± 1.0%																					
101 – 1.25%	101 ± 1.25%																					
110 – 1.5%	110 ± 1.5%																					
111 – 2.0%	111 ± 2.0%																					
4:2	SSC1_6 [2:0]	000b																				
1:0	SSC1_5 [2:1]	000b																				
11h	7	SSC1_5 [0]	000b																			
	6:4	SSC1_4 [2:0]																				
	3:1	SSC1_3 [2:0]																				
	0	SSC1_2 [2]																				
12h	7:6	SSC1_2 [1:0]	000b																			
	5:3	SSC1_1 [2:0]																				
	2:0	SSC1_0 [2:0]																				
13h	7	FS1_7	0b	FS1_x: PLL1 frequency selection ⁽⁴⁾ 0 – f_{VCO1_0} (predefined by PLL1_0 – multiplier or divider value) 1 – f_{VCO1_1} (predefined by PLL1_1 – multiplier or divider value)																		
	6	FS1_6	0b																			
	5	FS1_5	0b																			
	4	FS1_4	0b																			
	3	FS1_3	0b																			
	2	FS1_2	0b																			
	1	FS1_1	0b																			
	0	FS1_0	0b																			
14h	7	MUX1	1b	PLL1 multiplexer: 0 – PLL1 1 – PLL1 bypass (PLL1 is in power down)																		
	6	M2	1b	Output Y2 multiplexer: 0 – Pdiv1 1 – Pdiv2																		
	5:4	M3	10b	Output Y3 Multiplexer: 00 – Pdiv1-divider 01 – Pdiv2-divider 10 – Pdiv3-divider 11 – Reserved																		
	3:2	Y2Y3_ST1	11b	Y2, Y3-State0, State1 definition: 00 – Y2, Y3 disabled to high-impedance state (PLL1 is in power down) 01 – Y2, Y3 disabled to high-impedance state 10 – Y2, Y3 disabled to low 11 – Y2, Y3 enabled																		
	1:0	Y2Y3_ST0	01b																			
15h	7	Y2Y3_7	0b	Y2Y3_x output state selection. ⁽⁴⁾ 0 – State0 (predefined by Y2Y3_ST0) 1 – State1 (predefined by Y2Y3_ST1)																		
	6	Y2Y3_6	0b																			
	5	Y2Y3_5	0b																			
	4	Y2Y3_4	0b																			
	3	Y2Y3_3	0b																			
	2	Y2Y3_2	0b																			
	1	Y2Y3_1	1b																			
	0	Y2Y3_0	0b																			

- (1) Writing data beyond 20h may adversely affect device function.
 (2) All data is transferred MSB-first.
 (3) Unless a custom setting is used
 (4) The user can predefine up to eight different control settings. In normal device operation, these settings can be selected by the external control pins, S0, S1, and S2.

Table 10. PLL1 Configuration Register (continued)

OFFSET ⁽¹⁾	Bit ⁽²⁾	Acronym	Default ⁽³⁾	DESCRIPTION	
16h	7	SSC1DC	0b	PLL1 SSC down and center selection:	0 – Down 1 – Center
	6:0	Pdiv2	01h	7-bit Y2-output-divider Pdiv2:	0 – Reset and stand-by 1 to 127 – Divider value
17h	7	—	0b	Reserved – do not write others than 0	
	6:0	Pdiv3	01h	7-bit Y3-output-divider Pdiv3:	0 – Reset and stand-by 1 to 127 – Divider value
18h	7:0	PLL1_0N [11:4]	004h	PLL1_0 ⁽⁵⁾ : 30-bit multiplier or divider value for frequency f_{VCO1_0} (for more information, see the <i>PLL Multiplier or Divider Definition</i> paragraph).	
19h	7:4	PLL1_0N [3:0]			
	3:0	PLL1_0R [8:5]	000h		
1Ah	7:3	PLL1_0R[4:0]	10h		
	2:0	PLL1_0Q [5:3]			
1Bh	7:5	PLL1_0Q [2:0]	010b		
	4:2	PLL1_0P [2:0]			
	1:0	VCO1_0_RANGE		00b	f_{VCO1_0} range selection: 00 – $f_{VCO1_0} < 125$ MHz 01 – $125 \text{ MHz} \leq f_{VCO1_0} < 150$ MHz 10 – $150 \text{ MHz} \leq f_{VCO1_0} < 175$ MHz 11 – $f_{VCO1_0} \geq 175$ MHz
1Ch	7:0	PLL1_1N [11:4]	004h	PLL1_1 ⁽⁵⁾ : 30-bit multiplier or divider value for frequency f_{VCO1_1} (for more information see the <i>PLL Multiplier or Divider Definition</i>).	
1Dh	7:4	PLL1_1N [3:0]			
	3:0	PLL1_1R [8:5]	000h		
1Eh	7:3	PLL1_1R[4:0]	10h		
	2:0	PLL1_1Q [5:3]			
1Fh	7:5	PLL1_1Q [2:0],	010b		
	4:2	PLL1_1P [2:0]			
	1:0	VCO1_1_RANGE		00b	f_{VCO1_1} range selection: 00 – $f_{VCO1_1} < 125$ MHz 01 – $125 \text{ MHz} \leq f_{VCO1_1} < 150$ MHz 10 – $150 \text{ MHz} \leq f_{VCO1_1} < 175$ MHz 11 – $f_{VCO1_1} \geq 175$ MHz

(5) PLL settings limits: $16 \leq q \leq 63$, $0 \leq p \leq 7$, $0 \leq r \leq 511$, $0 < N < 4096$

PLL Multiplier or Divider Definition

At a given input frequency (f_{IN}), the output frequency (f_{OUT}) of the CDCE913-Q1 or CDCEL913-Q1 can be calculated:

$$f_{OUT} = \frac{f_{IN}}{Pdiv} \times \frac{N}{M} \quad (1)$$

where

M (1 to 511) and N (1 to 4095) are the multiplier or divide values of the PLL; Pdiv (1 to 127) is the output divider.

The target VCO frequency (f_{VCO}) of each PLL can be calculated:

$$f_{VCO} = f_{IN} \times \frac{N}{M} \quad (2)$$

The PLL internally operates as fractional divider and needs the following multiplier or divider settings:

- N
- $P = 4 - \text{int} \left(\log_2 \frac{N}{M} \right)$ [if $P < 0$ then $P = 0$]
- $Q = \text{int} \left(\frac{N'}{M} \right)$
- $R = N' - M \times Q$

where

$$\begin{aligned} N' &= N \times 2^P \\ N &\geq M \\ 80 \text{ MHz} &\leq f_{VCO} \leq 230 \text{ MHz} \\ 16 &\leq q \leq 63 \\ 0 &\leq p \leq 4 \\ 0 &\leq r \leq 51 \end{aligned}$$

Example:

for $f_{IN} = 27 \text{ MHz}$; $M = 1$; $N = 4$; $Pdiv = 2$

$$\begin{aligned} \rightarrow f_{OUT} &= 54 \text{ MHz} \\ \rightarrow f_{VCO} &= 108 \text{ MHz} \\ \rightarrow P &= 4 - \text{int}(\log_2 4) = 4 - 2 = 2 \\ \rightarrow N' &= 4 \times 2^2 = 16 \\ \rightarrow Q &= \text{int}(16) = 16 \\ \rightarrow R &= 16 - 16 = 0 \end{aligned}$$

for $f_{IN} = 27 \text{ MHz}$; $M = 2$; $N = 11$; $Pdiv = 2$

$$\begin{aligned} \rightarrow f_{OUT} &= 74.25 \text{ MHz} \\ \rightarrow f_{VCO} &= 148.50 \text{ MHz} \\ \rightarrow P &= 4 - \text{int}(\log_2 5.5) = 4 - 2 = 2 \\ \rightarrow N' &= 11 \times 2^2 = 44 \\ \rightarrow Q &= \text{int}(22) = 22 \\ \rightarrow R &= 44 - 44 = 0 \end{aligned}$$

The values for P, Q, R, and N' are automatically calculated when using TI Pro-Clock™ software.

PACKAGING INFORMATION

Orderable Device	Status (1)	Package Type	Package Drawing	Pins	Package Qty	Eco Plan (2)	Lead/Ball Finish	MSL Peak Temp (3)	Op Temp (°C)	Device Marking (4/5)	Samples
CDCE913QPWRQ1	PREVIEW	TSSOP	PW	14	2000	TBD	Call TI	Call TI	-40 to 125	CE913Q	
CDCEL913IPWRQ1	ACTIVE	TSSOP	PW	14	2000	Green (RoHS & no Sb/Br)	CU NIPDAU	Level-1-260C-UNLIM	-40 to 85	CEL913Q	Samples

(1) The marketing status values are defined as follows:

ACTIVE: Product device recommended for new designs.

LIFEBUY: TI has announced that the device will be discontinued, and a lifetime-buy period is in effect.

NRND: Not recommended for new designs. Device is in production to support existing customers, but TI does not recommend using this part in a new design.

PREVIEW: Device has been announced but is not in production. Samples may or may not be available.

OBSELETE: TI has discontinued the production of the device.

(2) Eco Plan - The planned eco-friendly classification: Pb-Free (RoHS), Pb-Free (RoHS Exempt), or Green (RoHS & no Sb/Br) - please check <http://www.ti.com/productcontent> for the latest availability information and additional product content details.

TBD: The Pb-Free/Green conversion plan has not been defined.

Pb-Free (RoHS): TI's terms "Lead-Free" or "Pb-Free" mean semiconductor products that are compatible with the current RoHS requirements for all 6 substances, including the requirement that lead not exceed 0.1% by weight in homogeneous materials. Where designed to be soldered at high temperatures, TI Pb-Free products are suitable for use in specified lead-free processes.

Pb-Free (RoHS Exempt): This component has a RoHS exemption for either 1) lead-based flip-chip solder bumps used between the die and package, or 2) lead-based die adhesive used between the die and leadframe. The component is otherwise considered Pb-Free (RoHS compatible) as defined above.

Green (RoHS & no Sb/Br): TI defines "Green" to mean Pb-Free (RoHS compatible), and free of Bromine (Br) and Antimony (Sb) based flame retardants (Br or Sb do not exceed 0.1% by weight in homogeneous material)

(3) MSL, Peak Temp. -- The Moisture Sensitivity Level rating according to the JEDEC industry standard classifications, and peak solder temperature.

(4) There may be additional marking, which relates to the logo, the lot trace code information, or the environmental category on the device.

(5) Multiple Device Markings will be inside parentheses. Only one Device Marking contained in parentheses and separated by a "~" will appear on a device. If a line is indented then it is a continuation of the previous line and the two combined represent the entire Device Marking for that device.

Important Information and Disclaimer: The information provided on this page represents TI's knowledge and belief as of the date that it is provided. TI bases its knowledge and belief on information provided by third parties, and makes no representation or warranty as to the accuracy of such information. Efforts are underway to better integrate information from third parties. TI has taken and continues to take reasonable steps to provide representative and accurate information but may not have conducted destructive testing or chemical analysis on incoming materials and chemicals. TI and TI suppliers consider certain information to be proprietary, and thus CAS numbers and other limited information may not be available for release.

In no event shall TI's liability arising out of such information exceed the total purchase price of the TI part(s) at issue in this document sold by TI to Customer on an annual basis.

OTHER QUALIFIED VERSIONS OF CDCE913-Q1, CDCEL913-Q1 :

- Catalog: [CDCE913](#), [CDCEL913](#)

NOTE: Qualified Version Definitions:

- Catalog - TI's standard catalog product

TAPE AND REEL INFORMATION



QUADRANT ASSIGNMENTS FOR PIN 1 ORIENTATION IN TAPE



*All dimensions are nominal

Device	Package Type	Package Drawing	Pins	SPQ	Reel Diameter (mm)	Reel Width W1 (mm)	A0 (mm)	B0 (mm)	K0 (mm)	P1 (mm)	W (mm)	Pin1 Quadrant
CDCEL913IPWRQ1	TSSOP	PW	14	2000	330.0	12.4	6.9	5.6	1.6	8.0	12.0	Q1

TAPE AND REEL BOX DIMENSIONS



*All dimensions are nominal

Device	Package Type	Package Drawing	Pins	SPQ	Length (mm)	Width (mm)	Height (mm)
CDCEL913IPWRQ1	TSSOP	PW	14	2000	367.0	367.0	35.0

PW (R-PDSO-G14)

PLASTIC SMALL OUTLINE

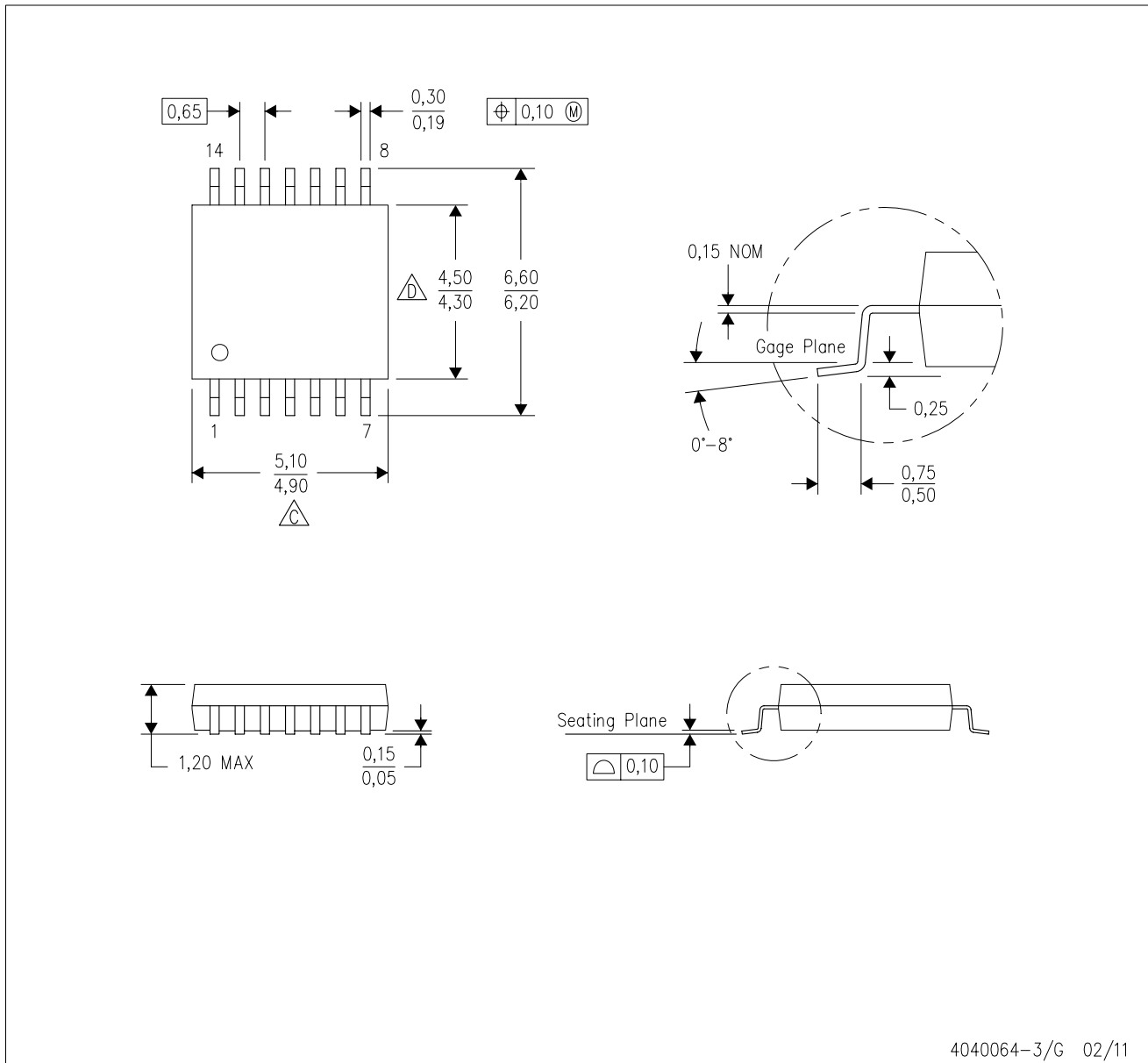

4040064-3/G 02/11

- NOTES:
- A. All linear dimensions are in millimeters. Dimensioning and tolerancing per ASME Y14.5M-1994.
 - B. This drawing is subject to change without notice.
 -  Body length does not include mold flash, protrusions, or gate burrs. Mold flash, protrusions, or gate burrs shall not exceed 0,15 each side.
 -  Body width does not include interlead flash. Interlead flash shall not exceed 0,25 each side.
 - E. Falls within JEDEC MO-153

PW (R-PDSO-G14)

PLASTIC SMALL OUTLINE

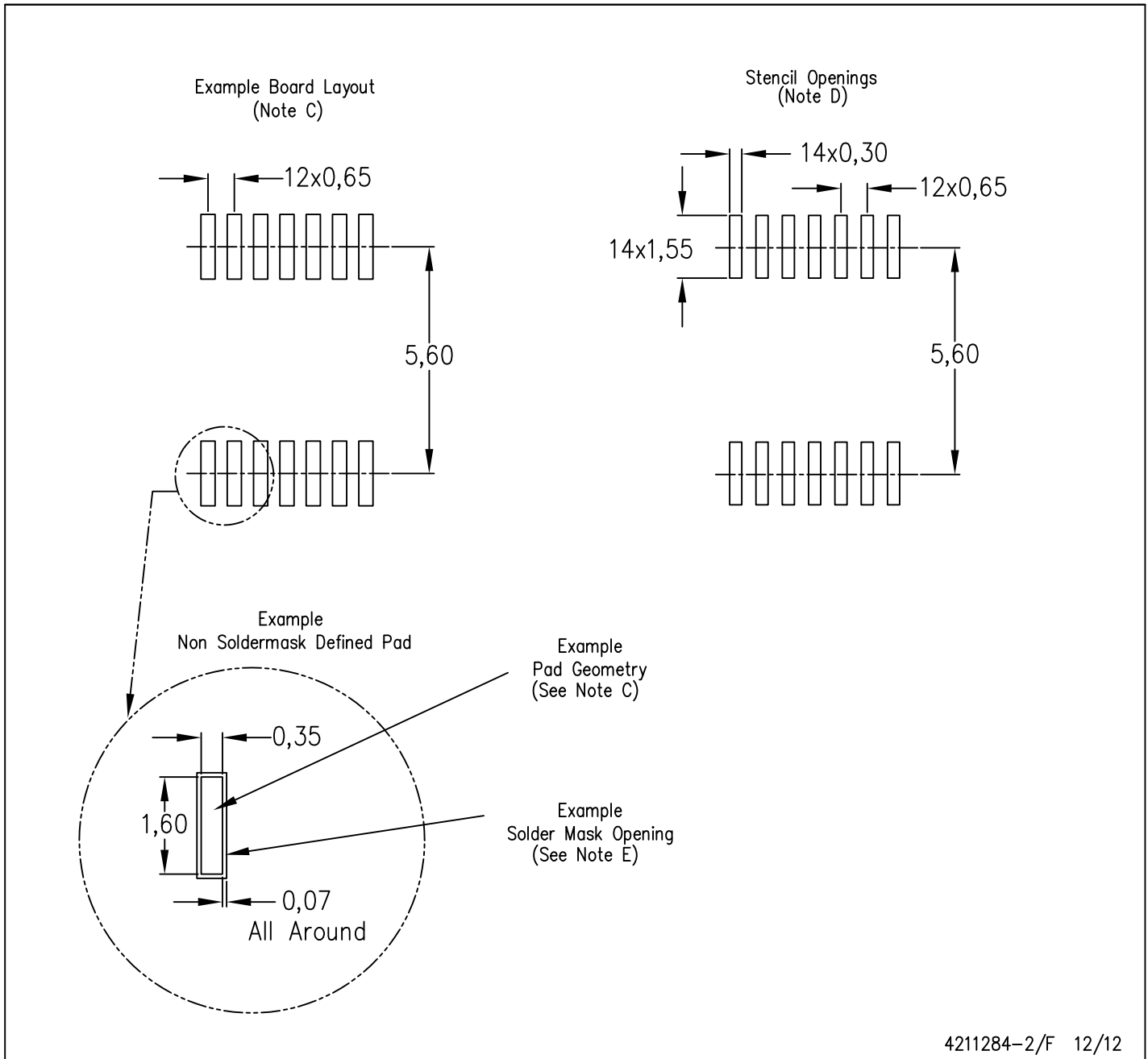

- NOTES:
- All linear dimensions are in millimeters.
 - This drawing is subject to change without notice.
 - Publication IPC-7351 is recommended for alternate designs.
 - Laser cutting apertures with trapezoidal walls and also rounding corners will offer better paste release. Customers should contact their board assembly site for stencil design recommendations. Refer to IPC-7525 for other stencil recommendations.
 - Customers should contact their board fabrication site for solder mask tolerances between and around signal pads.

IMPORTANT NOTICE

Texas Instruments Incorporated and its subsidiaries (TI) reserve the right to make corrections, enhancements, improvements and other changes to its semiconductor products and services per JESD46, latest issue, and to discontinue any product or service per JESD48, latest issue. Buyers should obtain the latest relevant information before placing orders and should verify that such information is current and complete. All semiconductor products (also referred to herein as "components") are sold subject to TI's terms and conditions of sale supplied at the time of order acknowledgment.

TI warrants performance of its components to the specifications applicable at the time of sale, in accordance with the warranty in TI's terms and conditions of sale of semiconductor products. Testing and other quality control techniques are used to the extent TI deems necessary to support this warranty. Except where mandated by applicable law, testing of all parameters of each component is not necessarily performed.

TI assumes no liability for applications assistance or the design of Buyers' products. Buyers are responsible for their products and applications using TI components. To minimize the risks associated with Buyers' products and applications, Buyers should provide adequate design and operating safeguards.

TI does not warrant or represent that any license, either express or implied, is granted under any patent right, copyright, mask work right, or other intellectual property right relating to any combination, machine, or process in which TI components or services are used. Information published by TI regarding third-party products or services does not constitute a license to use such products or services or a warranty or endorsement thereof. Use of such information may require a license from a third party under the patents or other intellectual property of the third party, or a license from TI under the patents or other intellectual property of TI.

Reproduction of significant portions of TI information in TI data books or data sheets is permissible only if reproduction is without alteration and is accompanied by all associated warranties, conditions, limitations, and notices. TI is not responsible or liable for such altered documentation. Information of third parties may be subject to additional restrictions.

Resale of TI components or services with statements different from or beyond the parameters stated by TI for that component or service voids all express and any implied warranties for the associated TI component or service and is an unfair and deceptive business practice. TI is not responsible or liable for any such statements.

Buyer acknowledges and agrees that it is solely responsible for compliance with all legal, regulatory and safety-related requirements concerning its products, and any use of TI components in its applications, notwithstanding any applications-related information or support that may be provided by TI. Buyer represents and agrees that it has all the necessary expertise to create and implement safeguards which anticipate dangerous consequences of failures, monitor failures and their consequences, lessen the likelihood of failures that might cause harm and take appropriate remedial actions. Buyer will fully indemnify TI and its representatives against any damages arising out of the use of any TI components in safety-critical applications.

In some cases, TI components may be promoted specifically to facilitate safety-related applications. With such components, TI's goal is to help enable customers to design and create their own end-product solutions that meet applicable functional safety standards and requirements. Nonetheless, such components are subject to these terms.

No TI components are authorized for use in FDA Class III (or similar life-critical medical equipment) unless authorized officers of the parties have executed a special agreement specifically governing such use.

Only those TI components which TI has specifically designated as military grade or "enhanced plastic" are designed and intended for use in military/aerospace applications or environments. Buyer acknowledges and agrees that any military or aerospace use of TI components which have **not** been so designated is solely at the Buyer's risk, and that Buyer is solely responsible for compliance with all legal and regulatory requirements in connection with such use.

TI has specifically designated certain components as meeting ISO/TS16949 requirements, mainly for automotive use. In any case of use of non-designated products, TI will not be responsible for any failure to meet ISO/TS16949.

Products

Audio	www.ti.com/audio
Amplifiers	amplifier.ti.com
Data Converters	dataconverter.ti.com
DLP® Products	www.dlp.com
DSP	dsp.ti.com
Clocks and Timers	www.ti.com/clocks
Interface	interface.ti.com
Logic	logic.ti.com
Power Mgmt	power.ti.com
Microcontrollers	microcontroller.ti.com
RFID	www.ti-rfid.com
OMAP Applications Processors	www.ti.com/omap
Wireless Connectivity	www.ti.com/wirelessconnectivity

Applications

Automotive and Transportation	www.ti.com/automotive
Communications and Telecom	www.ti.com/communications
Computers and Peripherals	www.ti.com/computers
Consumer Electronics	www.ti.com/consumer-apps
Energy and Lighting	www.ti.com/energy
Industrial	www.ti.com/industrial
Medical	www.ti.com/medical
Security	www.ti.com/security
Space, Avionics and Defense	www.ti.com/space-avionics-defense
Video and Imaging	www.ti.com/video

TI E2E Community

e2e.ti.com